

THERMAL RESISTANCE OF SHELLS OF VARIOUS CONFIGURATIONS

G. N. Dul'nev

Inzhenerno-Fizicheskii Zhurnal, Vol. 14, No. 4, pp. 609-614, 1968

UDC 536.21

A method is proposed for calculating the thermal resistances of shells of various configurations with allowance for the temperature dependence of the thermal conductivity of the material. Approximate formulas are presented for the thermal resistances of shells in the form of infinite prisms and parallelepipeds.

The one-dimensional heat flux through a closed shell

$$P = -\lambda(t) \frac{dt}{dx} S(x).$$

We reduce this expression to the form

$$-\frac{P dx}{S(x)} = \lambda(t) dt$$

and integrate it over the thickness of the wall from $x = l_1$ to $x = l_2$:

$$\int_{t_2}^{t_1} \lambda(t) dt = P \int_{l_1}^{l_2} \frac{dx}{S(x)}. \tag{1}$$

It is assumed that the heat flux remains unchanged in passing through the shell, i.e., there are no additional energy sources or sinks along its path. We apply the mean value theorem to the left side of (1):

$$\int_{t_2}^{t_1} \lambda dt = \lambda(\Theta)(t_1 - t_2), \quad t_1 \cong \Theta \cong t_2.$$

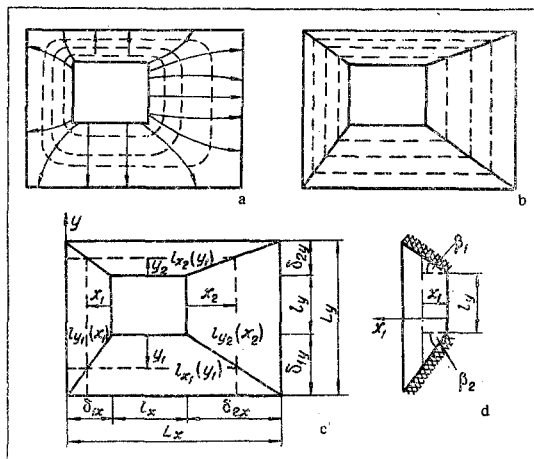

Fig. 1. Heat flow lines and isothermal surfaces of prismatic shell: a) actual pattern; b) schematized pattern; c) complete shell; d) part of shell.

Hence

$$\lambda(\Theta) \cong \bar{\lambda} = \frac{\int_{t_2}^{t_1} \lambda dt}{t_1 - t_2}. \tag{2}$$

We define the thermal resistance of the shell as

$$R = \frac{t_1 - t_2}{P} = \frac{1}{\bar{\lambda}} \int_{l_1}^{l_2} \frac{dx}{S(x)} \tag{3}$$

and find the corresponding expressions for an infinite

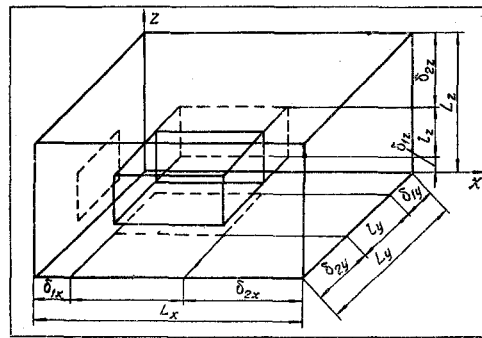

Fig. 2. Shell in the form of a parallelepiped.

plane wall, and infinite cylinder and a sphere. The areas of the isothermal surfaces are respectively

$$S_n = L_1 L_2, \quad S_L = 2\pi x L, \quad S_{sp} = 4\pi x^2,$$

where L_1 and L_2 are the length and width of the plane wall, and L the length of the cylindrical wall.

Substituting the expression for S in (3) and integrating, we obtain the known formulas

$$R_p = \frac{l_2 - l_1}{\bar{\lambda} L_1 L_2}, \quad R_{cy} = \frac{1}{2\pi \bar{\lambda} L} \ln \frac{l_2}{l_1},$$

$$R_{sp} = \frac{1}{4\pi \bar{\lambda}} \left(\frac{1}{l_1} - \frac{1}{l_2} \right). \tag{4}$$

We will find the thermal resistance of a shell in the form of an infinite prism of rectangular cross section. Figure 1 shows the cross section of an infinite prism containing a second infinite prism. We assume that the surfaces of the prisms are isothermal surfaces with temperatures t_1 and t_2 , and that the mean thermal conductivity of the wall material is equal to $\bar{\lambda}$. Calculating the thermal resistance of such a shell is a rather complicated problem, since the heat flux is not one-dimensional. Exact analytic methods would lead to clumsy expressions; accordingly, it is desirable to consider an approximate solution. Whereas the extreme isothermal surfaces are prismatic, the intermediate ones have a more complicated configuration: their corners are rounded, as shown in Fig. 1a. We

connect the edges of the inner and outer prisms with plane surfaces (Fig. 1b) and consider the nature of the heat flow lines in their neighborhood. In the first approximation it may be assumed that the heat flow lines do not intersect these surfaces, i. e., they may be assumed adiabatic. The prismatic shell was found to be divided into four parts, each of which can be considered separately. We also assume that, without much loss of accuracy, the intermediate isothermal surfaces can be regarded as plane and parallel to the edges of the prism, as shown in Fig. 1b. A comparison of Figs. 1a and 1b leads to the conclusion that there is little difference between the actual process and the model. Thus, the problem reduces to determining the thermal resistances of the individual parts of the prismatic shell, one of which is represented in Fig. 1d. The total thermal resistance of the prismatic shell consists of the four parallel-connected thermal resistances of the parts of the shell. In the bodies obtained by the method indicated the heat flux is one-dimensional, and there are no heat sources or sinks; therefore to determine the thermal resistance it is possible to apply Eq. (3). We denote the sides of the outer and inner rectangles by L_x , L_y , and l_x , l_y , and the thicknesses of the walls of the prismatic shell by δ_{1x} , δ_{2x} , δ_{1y} , δ_{2y} ; we introduce the variable coordinates x_1 , x_2 , y_1 , y_2 in each part of the prismatic wall (Fig. 1c). We will consider the left-hand part of the shell and denote the height of the plane isothermal surface at distance x_1 from the inner wall by $l_{y_1}(x_1)$; here the subscript y indicates that the surface is parallel to the y -axis. If the length of the prism is L , then the area of the isothermal surface is equal to Ll_{y_1} . Similar notation has been introduced for the intermediate isothermal surfaces of the other parts of the shell (Fig. 1c).

It follows from Fig. 1c and Fig. 1d that

$$\begin{aligned} l_{y_1}(x_1) &= l_y + x_1 \frac{L_y - l_y}{\delta_{x_1}}, & 0 \leq x_1 \leq \delta_{x_1}, \\ l_{y_2}(x_2) &= l_y + x_2 \frac{L_y - l_y}{\delta_{x_2}}, & 0 \leq x_2 \leq \delta_{x_2}, \\ l_{x_1}(y_1) &= l_x + y_1 \frac{L_x - l_x}{\delta_{y_1}}, & 0 \leq y_1 \leq \delta_{y_1}, \\ l_{x_2}(y_2) &= l_x + y_2 \frac{L_x - l_x}{\delta_{y_2}}, & 0 \leq y_2 \leq \delta_{y_2}. \end{aligned}$$

Substituting these expressions for the isothermal surfaces in (3) and integrating, we obtain expressions for the thermal resistances. For example, for the surface $Ll_{y_1}(x)$ we obtain

$$\begin{aligned} R_{y_1} &= \frac{1}{\bar{\lambda} L} \int_0^{\delta_{x_1}} \frac{dx_1}{l_y + x_1(L_y - l_y) \frac{1}{\delta_{x_1}}} = \\ &= \frac{\delta_{x_1} \ln \frac{L_y}{l_y}}{\bar{\lambda} L (L_y - l_y)}. \end{aligned} \quad (5)$$

It is possible to write a generalized expression for the isothermal surface

$$Ll_{\eta_i}(\varepsilon_i) = \left(l_{\eta} + \varepsilon_i \frac{L_{\eta} - l_{\eta}}{\delta_{\varepsilon_i}} \right) L \quad (6)$$

and the thermal resistance R_{η_i} :

$$R_{\eta_i} = \frac{\delta_{\varepsilon_i}}{\bar{\lambda} L (L_{\eta} - l_{\eta})} \ln \frac{L_{\eta}}{l_{\eta}}. \quad (7)$$

In (6) and (7) the parameters ε , η , and i have the following values:

$$\eta = x, y, \quad \varepsilon = y, x, \quad \varepsilon \neq \eta, \quad i = 1 \text{ or } 2. \quad (8)$$

Using (7) and (8), we write expressions for the thermal resistances of each of the four parts of the shell and add their reciprocal values (parallel connection). As a result we obtain an expression for the thermal resistance of the entire prismatic shell. The reciprocal of R , i. e., the thermal conductance σ of the prismatic shell, has the form

$$\begin{aligned} \sigma &= \bar{\lambda} L (L_x - l_x) (L_y - l_y) \times \\ &\times \left(\frac{1}{\delta_{y_1} \delta_{y_2} \ln \frac{L_x}{l_x}} + \frac{1}{\delta_{x_1} \delta_{x_2} \ln \frac{L_y}{l_y}} \right). \end{aligned} \quad (9)$$

If the thicknesses of all the parts of the prismatic shell are the same and equal to δ , from (9) we obtain

$$\sigma = 4\bar{\lambda} L \left(\frac{1}{\ln \frac{L_x}{l_x}} + \frac{1}{\ln \frac{L_y}{l_y}} \right). \quad (10)$$

If, moreover, both prisms are square in cross section, we find that

$$\sigma = \frac{8\bar{\lambda} L}{\ln \frac{L_x}{l_x}}. \quad (11)$$

We will employ the method proposed for prismatic shells to determine the thermal resistance of a shell in the form of a parallelepiped. For this purpose we connect with plane surfaces the opposite edges of the inner and outer parallelepipeds (Fig. 2). Because of the nature of the heat streamlines, in first approximation the surfaces introduced can be assumed adiabatic; then the parallelepiped is divided into six truncated pyramids, whose thermal resistances can be considered separately.

We will find an analytic expression for the area of the intermediate rectangular isothermal surface. For this purpose we write the expressions for the sides of the rectangle in generalized form (6),

$$\begin{aligned} l_{\varepsilon_i}(\gamma_i) &= l_{\varepsilon} + \gamma_i \frac{L_{\varepsilon} - l_{\varepsilon}}{\delta_{\gamma_i}}, \\ l_{\eta_i}(\gamma_i) &= l_{\eta} + \gamma_i \frac{L_{\eta} - l_{\eta}}{\delta_{\gamma_i}}, \end{aligned}$$

where

$$\begin{aligned} \gamma &= x, y, z, & \gamma \neq \varepsilon \neq \eta, \\ \varepsilon &= y, z, x, & i = 1 \text{ or } 2. \\ \eta &= z, x, y, \end{aligned}$$

The intermediate isothermal surface has the form of a rectangle. Therefore

$$S(\gamma_i) = l_{e_i}(\gamma_i)l_{\eta_i}(\gamma_i). \tag{12}$$

Substituting the value of the area $S(\gamma_i)$ in (3) and integrating, we obtain a general expression for the thermal resistance R_{γ_i} of one part of the shell:

$$R_{\gamma_i} = \frac{1}{\lambda} \int_0^{\gamma_i} \frac{d\gamma_i}{S(\gamma_i)} = \frac{\delta_{\gamma_i} \ln \frac{L_{\eta} l_e}{L_e l_{\eta}}}{\lambda (L_{\eta} l_e - L_e l_{\eta})}. \tag{13}$$

The reciprocal of the thermal resistance $\sigma_{\gamma_i} = (R_{\gamma_i})^{-1}$ is the thermal conductance of one of the six parts of the shell. Adding the thermal conductances of all the parts of the shell, for the thermal conductance σ of a shell in the form of a parallelepiped we obtain

$$\frac{\sigma}{\lambda} = \frac{(L_z l_y - L_y l_z)(L_x - l_x)}{\delta_x \delta_{x_2} \ln \frac{L_z l_y}{L_y l_z}} + \frac{(L_x l_z - L_z l_x)(L_y - l_y)}{\delta_{y_1} \delta_{y_2} \ln \frac{L_x l_z}{L_z l_x}} + \frac{(L_y l_x - L_x l_y)(L_z - l_z)}{\delta_{z_1} \delta_{z_2} \ln \frac{L_y l_x}{L_x l_y}}. \tag{14}$$

The geometric parameters in (14) are indicated in Fig. 2.

If the thicknesses of all six walls of the shell are the same, then

$$\delta_{x_i} = \delta_{y_i} = \delta_{z_i} = \delta,$$

$$L_x - l_x = L_y - l_y = L_z - l_z = 2\delta$$

and (14) takes the simpler form

$$\frac{\sigma \delta}{2\lambda} = \frac{L_z l_y - L_y l_z}{\ln \frac{L_z l_y}{L_y l_z}} + \frac{L_x l_z - L_z l_x}{\ln \frac{L_x l_z}{L_z l_x}} + \frac{L_y l_x - L_x l_y}{\ln \frac{L_y l_x}{L_x l_y}}. \tag{15}$$

If it is assumed that both parallelepipeds have the form of a cube and that the wall thicknesses of the cubic shell are the same, Eq. (15) takes the form

$$\sigma = \frac{6Ll}{\delta} \bar{\lambda}. \tag{16}$$

We will compare (16) with the thermal conductance of a spherical shell whose value is easily obtained from (4):

$$\sigma_{sp} = \frac{1}{R_{sp}} = 6.28 \frac{Ll}{\delta} \bar{\lambda}, \tag{17}$$

where

$$L = l_2, \quad l = l_1, \quad (l_2 - l_1) = 2\delta.$$

The values of σ calculated from (16) and (17) differ by less than 5%.

Equations (9) and (14) for the thermal resistances of shells in the form of a prism and a parallelepiped can

also be used if the thermal conductivities of the different walls are not the same. In this case each component of the thermal conductances of the parts of the shell must be written with its own value of the thermal conductivity coefficient.

The proposed method can also be applied to shells of other configurations.

In conclusion we note that if the wall thicknesses are the same the thermal resistance of shells in the form of a parallelepiped can be calculated from the formulas proposed in 1913 by Langmuir, Adams, and Michael [2]. These formulas were established for various special cases on the basis of an approximation of the numerical data obtained from experiments on electrical models, i. e., the formulas may be regarded as empirical. It should be noted that the authors did not give the accuracy of these formulas; therefore they should be used cautiously. Nonetheless, it is of interest to compare values of the thermal conductance calculated from (15), (16) and from Langmuir's formulas. For a shell in the form of a cube with $l/\delta \geq 0.2$, we obtained the following results: when $0.2 \leq l/\delta \leq 1.0$ the data of the calculations differ by from 0 to 30%, and when $1.0 \leq l/\delta \leq 3$ by from 30% to 0. For shells in the form of a parallelepiped similar results were obtained, the values of the conductance calculated from the empirical formulas being too low as compared with those calculated from (15) and (16). The thermal conductances calculated for a plane angle from (9) and found graphically differ by not more than 6%.

It would be desirable to make a computer investigation of the thermal resistance of shells in the form of a parallelepiped and compare the results with both the approximate analytic relations and Langmuir's formulas.

NOTATION

P is the heat flux; λ is the thermal conductivity of the material at temperature t ; $\bar{\lambda}$ is the mean thermal conductivity; $S(x)$ is the area of the isothermal surface at a distance x from the origin; R and σ are the thermal resistance and thermal conductance of shell; l_i and L_i denote the length of side i of inside and outside parallelepipeds or prisms.

REFERENCES

1. G. M. Kondrat'ev, Thermal Measurements [in Russian], Mashgiz, 1957.
2. P. Schneider, Conduction Heat Transfer [Russian translation], IL, 1960.

16 June 1967

Institute of Precision Mechanics and Optics, Leningrad